

Thermodynamics Design Project: Fall 2008

Salt Water Desalination

1 Introduction

Water desalination is the process of producing drinkable water from brine. The primary input to a desalination plant is usually seawater, although brackish groundwater may also be used. Approximately 60% of the world's desalination plants are found in the Middle East. The Shoaiba desalination plant in Saudi Arabia is the largest desalination plant in the world produces and produces over 150 million m^3 of fresh water per year. The cost to build this plant was approximately \$1.06 billion. Only a limited number of desalination facilities operate in the United States due to the high cost of desalination compared to groundwater pumping from water-rich areas to those in need.



Figure 1: Shoaiba desalination facility. Image from: <http://www.water-technology.net/projects/shuaiba/shuaiba1.html>

This project consists of two major components. In the first, groups are to solve the material and energy balances for the included reference case. After successfully completing this assign-

ment, groups are to develop an optimized multi-stage flash process capable of producing 15,840 m³/day of fresh water.

To aid in the writing of the report, it is suggested that students obtain a copy of “Writing Style and Standards in Undergraduate Reports,” by Sheldon Jeter and Jeffrey Donnell, ISBN 0-9679121-7-2. This text is required for the lab courses ChE 3220 and ChE 3820.

2 Reference Design

A process flow diagram for the reference design can be found in Figure 2. Methane at 20 °C is mixed with 30% excess air and burned in the boiler. Heat from the combustion of methane is used to turn the liquid water feed (20 °C) into saturated steam at 140 °C. The fractional conversion of methane is 90%. Exhaust gases leave the boiler at 265 °C. Seawater, containing 3.5 wt% NaCl, is fed to a heat exchanger, where it absorbs heat from the condensing steam. The partially condensed steam leaves the heat exchanger at 60 °C and 1.01 bar. The heated seawater (120 °C, 2.0 bar) is fed to a series of flash evaporators, operating at pressures of 1.2, 0.6 and 0.1 bar. Water vaporized in each evaporator is combined and condensed. Fresh water is produced at a rate of 15,840 m³/day. **Determine the flowrates of all streams and the cost of operating this process.**

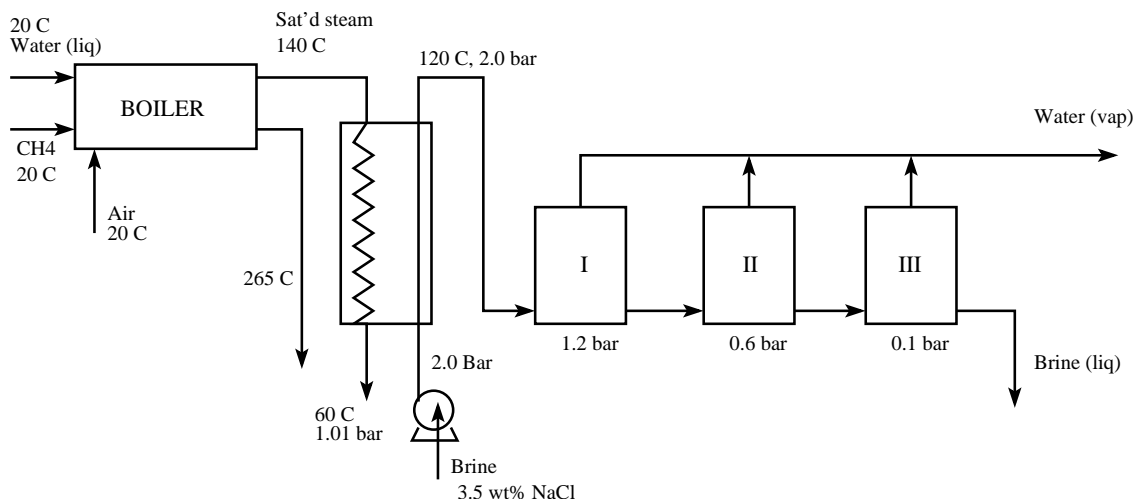

Figure 2: Reference design for multi-stage flash desalination.

3 Deliverables

1. **DUE 10/5/08:** 50% of project grade (30% technical content, 20% report): Completed the reference design, which includes:
 - (a) A clearly labeled process flow diagram.
 - (b) A table listing all process flow rates, with labels consistent with the process flow diagram.
 - (c) A 1-2 page description of all assumptions made and methods used for calculations.
 - (d) An organized and complete set of calculations. These may be done by hand or in Excel or MathCAD.
 - (e) Students are to submit their work electronically via Blackboard, and on paper at the beginning of class on 10/5/08.
 - (f) Late projects will receive a grade reduction of 5% per day.
2. **DUE 11/24/2008:** 50% of project grade (30% technical content, 20% report): Final report. Length of text and figures in the body of the report is restricted to 15 pages. The report consists of:
 - (a) Abstract
 - A summary of your most important results.
 - (b) Introduction
 - State the problem to be solved in your own words. Should be at least 1/2 page.
 - (c) Results and discussion
 - i. Results are to be presented as tables or graphs.
 - ii. Text will describe methods used to calculate each quantity and any assumptions that were made.
 - iii. Discussion is used to explain results. Why was a particular design chosen? What are the pros and cons?
 - iv. Cost analysis is also part of the results and discussion section.
 - (d) Conclusions
 - (e) References
 - References include the source of any equations used, cost data, graphics or pictures not created by you.
 - (f) Process flow diagrams and process description
 - (g) Numerical calculations
 - (h) Cost analysis

3.1 Grading

1. 60% technical content, 40% written report.
2. Complete solution of the reference case is necessary for a passing grade on this assignment.
3. Spelling and/or grammatical errors will result in a 2% reduction in grade per error.
4. Expectations for specific aspects of the report can be found in the included report grading rubric.

3.2 Group Assignments

1. Group #1: Bradley Crooker, Edward Richardson, Tadewos Woldemariam, Jesse Vilanueva
2. Group #2: Antoinette Klempay, Vladimir Tamahkyarov, Archana Manoharan, Lucas Wells
3. Group #3: Ashley Walker, Rebecca Lindsey Matt Poselli, Ali Assi
4. Group #4: James Simpson, Michelle Pizzini, Jon Zatkoff

Table 1: Report grading rubric

Criteria	Exemplary	Proficient	Marginal	Unacceptable
Description of problem	Concise presents the goals and constraints of the project.	Has the major elements of the project goals but may be missing minor details.	Present, but is vague, or fails to concisely report the technical purpose of the project.	Missing or poorly written by the author.
Solution to problem	Describes a complete solution to the problem, including a recommendation to build or not build. Summarizes major points to be covered in detail in the body of the report.	Mostly describes a solution that meets the requirements but is missing some information	Present, but is vague. Leaves the reader unclear about what the final solution is, or how it would be implemented.	Missing, or fails to discuss what was designed.
Pros and cons of alternative design schemes.	Describes in detail the pros and cons of various methods, and the reason the optimal design was chosen. References to external sources are made when appropriate.	Describes pros and cons of various methods, but may lack justification or references for certain decisions.	Misses large technical categories that should have been considered. Limited references to external sources, or poorly organized.	Missing or lacking all references. Pros and cons of alternative processes not discussed.
Process description	Completely describes the flow of energy and materials through the process. Flow rates and important temperatures and pressures for all streams and equipment are tabulated and referenced on the process flow diagram. Refers to appendices for supporting calculations.	Describes process flow diagram, but minor pieces of information are missing. Has a logical description of how materials move through the process.	Present, but does not include many flow rates or streams. Description does not match stream tables or process flow diagram.	Missing, or does not match the process flow diagram and stream table. Does not refer to appendices for calculations. Devoid of logical flow.
Process flow diagram (PFD)	All equipment and streams are clearly and properly labeled. PFD is consistent with the stream table.	PFD contains minor errors in labeling.	PFD is missing labels or is confused.	PFD contains major errors, or is inconsistent with the stream table.

Table 2: Report grading rubric

Criteria	Exemplary	Proficient	Marginal	Unacceptable
Stream table	Stream table is logically organized and matches PFD. Temperature, pressure, and flow rate information is present. Units are listed clearly in all cases.	Stream table similar to the exemplary case, but has minor errors.	Stream table contains significant relevant information, but is missing key data or illogically organized.	Stream table is missing, units not clear, does not match PFD, or is poorly organized.
Raw material and utility requirements	Lists all raw materials that enter the process, including water and air. Has units and sources listed for all materials.	List most of the materials, but many not match some of the other report information, such as the PFD or stream table.	No units and does not list sources. May be missing some utilities or does not match appendices.	Missing, does not refer to appendices, no units and does not reflect other information in report.
Economic Analysis	Reports overall equipment costs, utility costs and raw materials. Gives yes/no recommendation on the project. Sensitivity analysis is performed on major inputs to the process. Sources of cost information are listed.	Missing some categories. Gives a yes/no recommendation on the project.	Leaves out many details or is simply a "data dump". Fails to give a recommendation of yes or no.	Is missing or does not convey enough information to make an informed go, no-go decision.
Appendices	Organized in separate sections, references are made for calculations. Calculations are clear with no missing steps.	Meets most of the exemplary criteria.	Present, but lacking organization and or missing references. May be missing some major sections.	Totally unorganized or illegible.
Assumptions	Lists all major assumptions used in the design process with references to support them.	List most major assumptions with a few references to support claims.	A partial list of major assumptions but may be missing references.	Missing.
References	Includes all relevant references in correct format and referred to in the appropriate sections in the text.	Some minor problems with format or use in the text.	Many errors.	Missing or not referenced in the text at all.

Table 3: Report grading rubric

Criteria	Exemplary	Proficient	Marginal	Unacceptable
Detailed calculations	Calculations are thorough, legible, organized in a logical fashion and contain references for formulas. A reader familiar with the process would be able to quickly spot mistakes and could reproduce all of the work presented. All intermediate numbers are supported by referenced data.	Some detail is missing from the exemplary case or equations can be followed with difficulty.	Present, but missing so much detail that they cannot be independently verified.	Missing, completely disorganized, no units and irreproducible.
Grammar	No typographical, grammatical or spelling errors.	More than 2 typographical, grammatical or spelling errors.	More than 3 typographical, grammatical or spelling errors.	More than 5 typographical, grammatical or spelling errors.
Presentation	Report is clearly organized, printed on paper of uniform quality with clear, laser printed text. Figures are reproduced clearly. All pages are numbered consecutively. Report is stapled or held together with a binder clip. Report is not bound.	Minor deviations from the exemplary case.	Report contains mismatched paper.	Report is folded, wrinkled, etc. Dirty. No staple or binder clip.